

STUDYING PEDIGREES ACTIVITY

Introduction: A **pedigree** is a visual chart that depicts a family history or the transmission of a specific trait. They can be interesting to view and can be important tools in determining patterns of inheritance of specific traits. Pedigrees are used primarily by genetic counselors when helping couples decide to have children when there is evidence of a genetically inherited disorder in one or both families. They are also used when trying to determine the predisposition of someone to carry a hereditary disease for example, familial breast cancer.

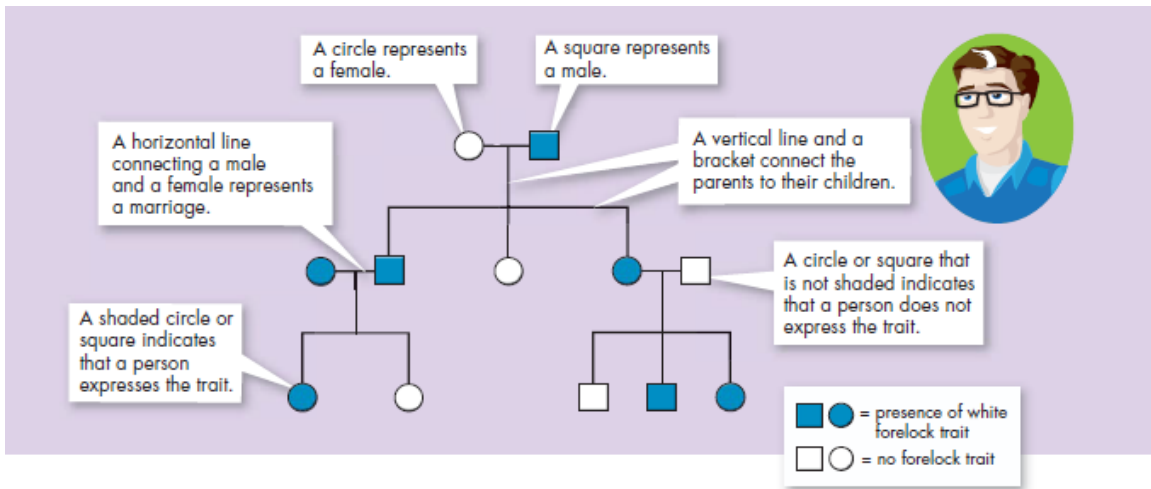

Copyright © Pearson Education, Inc., or its affiliates. All Rights Reserved.

The Components of a Pedigree:

Squares are used to indicate males in a family.



Circles are used to indicate females.



If the individual is "affected" by the trait (dominant or recessive) we darken the shape.



A line between a male and a female indicates a marriage or union.



A line drawn down from the marriage line indicates offspring.

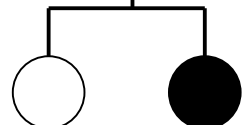

Sometimes, you will see some shapes filled in only half way - this notation indicates a *hybrid* (heterozygous) or *carrier* of the trait.



Analyzing Simple Pedigrees:

A pedigree is just like a family tree except that it focuses on a specific genetic trait. A pedigree usually only shows the phenotype of each family member. With a little thought, and the hints below, you may be able to determine the genotype of each family member as well!

Hints for analyzing pedigrees:

- 1) If the individual is homozygous recessive, then both parents **MUST** have at least one recessive allele (parents are heterozygous or homozygous recessive).
- 2) If an individual shows the dominant trait, then at least one of the parents **MUST** have the dominant phenotype. This one will be pretty obvious when you look at the pedigree.
- 3) If both parents are homozygous recessive, then **ALL** offspring will be homozygous recessive.

NOTE: In a pedigree, the trait of interest can be *dominant or recessive*. The majority of harmful genetic conditions are only seen when an individual is homozygous recessive - examples of conditions caused by recessive alleles include cystic fibrosis (a disease of the secretory glands, including those that make mucus and sweat), Falconi anemia (a blood disorder), albinism (a lack of pigmentation), and phenylketonuria (a metabolic disorder). Some genetic conditions are caused by dominant alleles (and may therefore be expressed in homozygous dominant or heterozygous individuals)- examples of conditions caused by dominant alleles include polydactyly (presence of extra fingers), achondroplasia (a type of dwarfism), neurofibromatosis (a nervous disorder), and a disease known as familial hypercholesterolemia in which affected individuals suffer from heart disease due to abnormally high cholesterol levels

Human Pedigrees

For Questions 1-9, use the pedigree chart shown below. Some of the labels may be used more than once.

_____ 1. A male

_____ 2. A female

_____ 3. A marriage

_____ 4. A person who expresses the trait

_____ 5. A person who does not express the trait

_____ 6. A connection between parents and offspring

_____ 7. How many generations are shown on this chart?

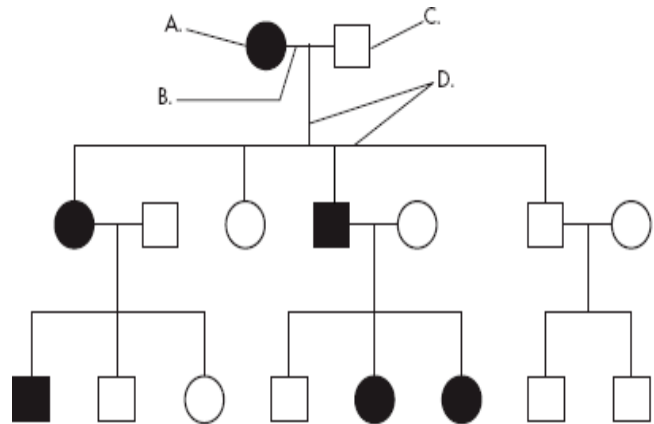

Assuming the chart above is tracing the dominant trait of "White Forelock (F)" through the family. F is a tuft of white hair on the forehead.

_____ 8. What is the most likely genotype of individual "A"? (FF, Ff or ff?)

_____ 9. What is the most likely genotype of individual "C"? (FF, Ff or ff?)

Example 1: Tracing the path of an autosomal recessive trait

Trait: Falconi anemia

Forms of the trait:

- ⤴ The **dominant** form is normal bone marrow function - in other words, no anemia.
- ⤴ The **recessive** form is Falconi anemia. Individuals affected show slow growth, heart defects, possible bone marrow failure and a high rate of leukemia.

A **typical pedigree** for a family that carries Falconi anemia. Note that carriers are **not** indicated with half-colored shapes in this chart.

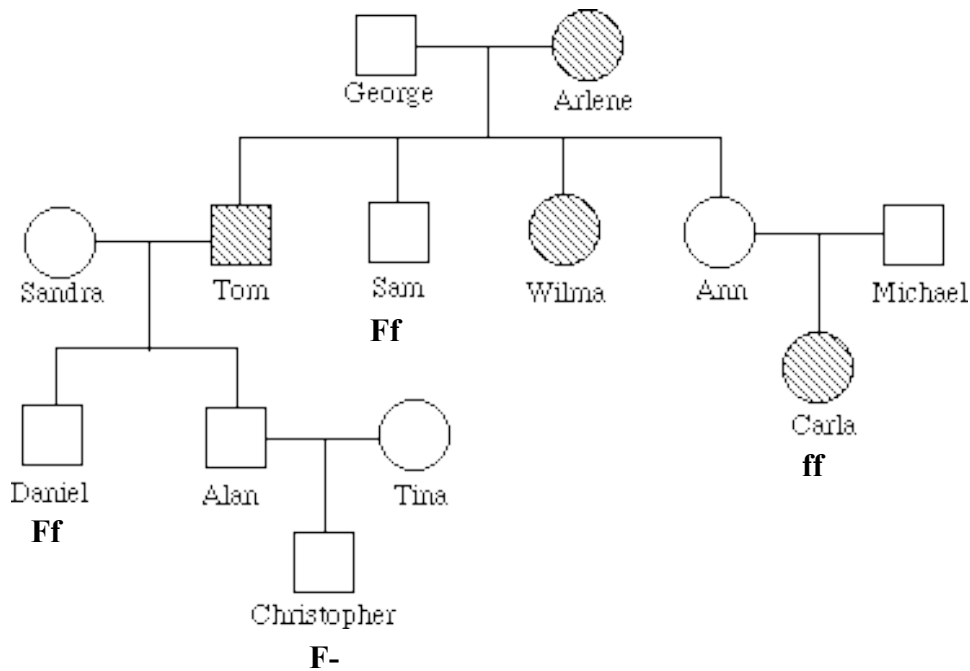

Analysis Questions.

To answer questions #1-5, use the letter "f" to indicate the recessive Falconi anemia allele, and the letter "F" for the normal allele.

1. What is Arlene's genotype? _____
2. What is George's genotype? _____
3. What are Ann & Michael's genotypes? _____
4. Most likely, Sandra's genotype is _____.
5. List three people from the chart (other than George) who are most likely *carriers* of Falconi anemia.

***Example 2: Tracing the path of an autosomal dominant trait**

Trait: Neurofibromatosis

Forms of the trait:

- ⤴ The **dominant** form is neurofibromatosis, caused by the production of an abnormal form of the protein neurofibromin. Affected individuals show spots of abnormal skin pigmentation and non-cancerous tumors that can interfere with the nervous system and cause blindness. Some tumors can convert to a cancerous form.
- ⤴ The **recessive** form is a normal protein - in other words, no neurofibromatosis.

A **typical pedigree** for a family that carries neurofibromatosis is shown below. Note that carriers are **not** indicated with half-colored shapes in this chart. Use the letter "N" to indicate the dominant neurofibromatosis allele, and the letter "n" for the normal allele.

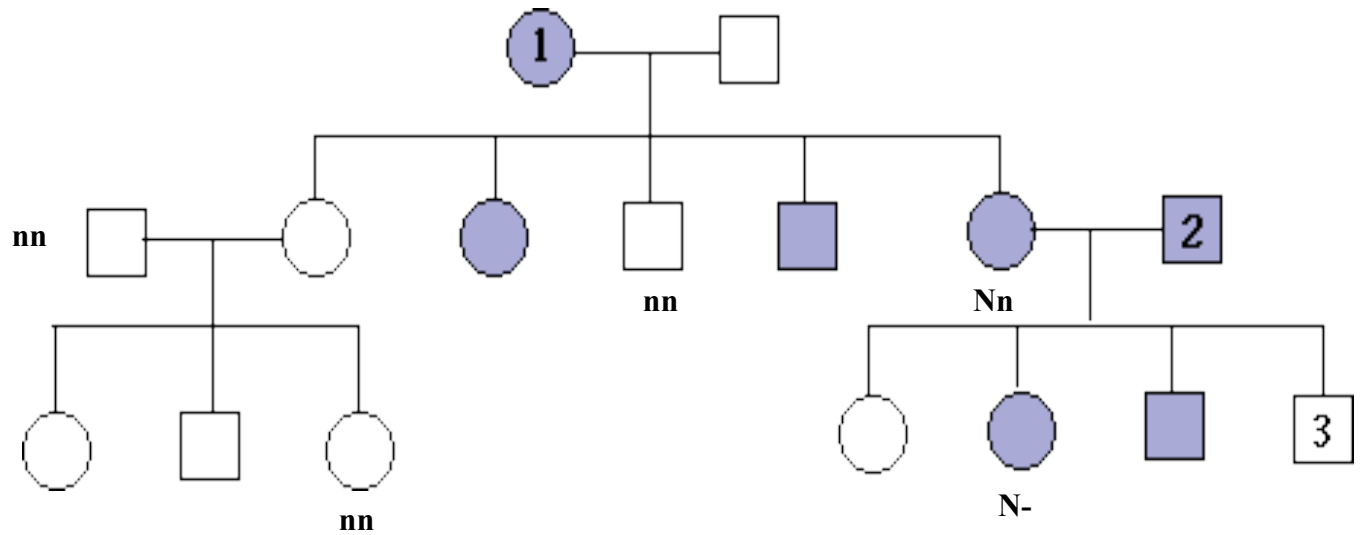

Analysis Questions:

1. Is individual #1 most likely homozygous dominant or heterozygous? Explain how you can tell. _____

2. What is the genotype of individual #3? _____

3. Can you be sure of the genotypes of the affected siblings of individual #3? Explain.

***YOUR TURN!!**

Instructions:

1. Draw a pedigree showing all the individuals described in the problem. (Include their names if given.)
2. Label the genotypes of as many individuals in the pedigree as possible.
3. Shade in half of the symbol if you know that the individual is heterozygous or a carrier.

***Draw your own Pedigree - Case study #1:**

Condition of Interest: Albinism

*Albinism is a condition in which there is a mutation in one of several possible genes, each of which helps to code for the protein **melanin**. This gene is normally active in cells called melanocytes which are found in the skin and eyes. Albinism involves a significant reduction or absence of the production of melanin, giving affected individuals a lack of normal coloration to their skin/eyes.*

Inheritance Pattern: normal melanin protein is produced by an autosomal dominant allele; albinism results from a lack of melanin and is caused by **an autosomal recessive allele**.

Use the letter **A** or **a** to represent dominant/recessive forms of albinism.

Two normally-pigmented parents have 3 children. The first child (a girl) and their second child (a boy) have normal pigmentation. Their third child (a girl) has albinism. That girl marries a normally pigmented male and they have four children. The first three (two girls and a boy) have normal pigmentation. Their fourth child (a girl) has albinism like her mother.

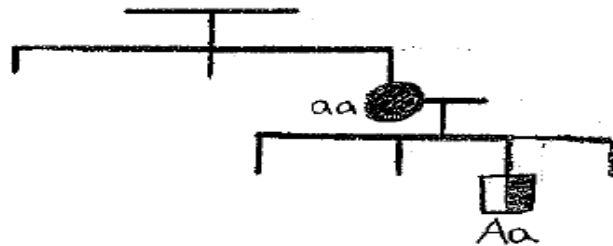

***Draw your own Pedigree - Case Study #2:**

Condition of Interest: Huntington's Disease (also known as HD or Huntington's chorea)

Huntington's disease is a neurodegenerative genetic disorder that affects muscle coordination and leads to cognitive decline and dementia.

Inheritance Pattern: the allele for the normal "Huntingtin" protein is **autosomal recessive**; Huntington's disease is caused by **an autosomal dominant allele** which codes for an abnormal form of the "Huntingtin" protein. Symptoms are more severe in homozygous individuals.

Use **H** or **h** to represent the alleles.

A normal man (Joseph) marries a woman (Rebecca) who is heterozygous for HD and they have four children. Two of their sons (Adam and Charles) are born healthy without HD. Charles marries a woman without HD and they have a normal daughter. Joseph and Rebecca's daughter Tasha and their last son (James) both have HD. James marries a non-HD woman whose sister and parents also do not suffer from HD. James and his wife have three children - a normal boy, a normal girl, and a son with HD.

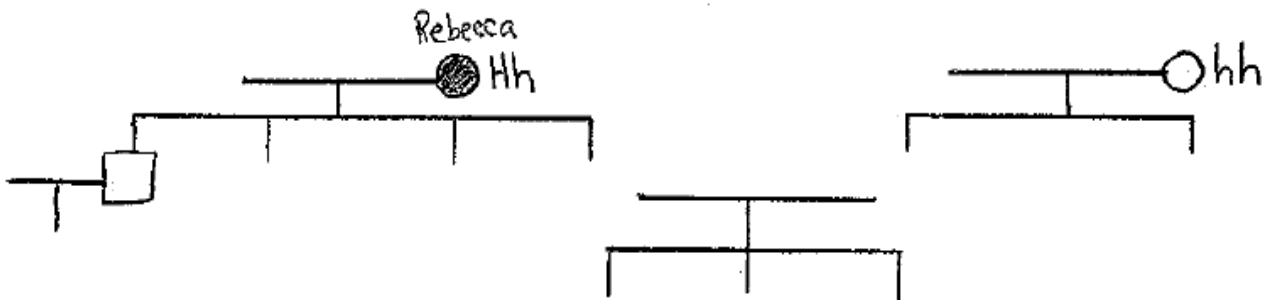

***Draw Your Own Pedigree - Case Study#3:**

Trait: blood type

Blood type is determined by the presence of several different proteins found on the surface of red blood cells. Blood type "A" has the A protein; blood type "B" has the B protein; blood type AB has both; blood type O has neither. The +/- indicates another protein called Rh.

Forms of the trait: inheritance via autosomal multiple allelism (A, B, or O) results in the blood types A, B, AB or O. The alleles for blood protein A and B are codominant, the "O" allele is recessive to both the A and B alleles.

Use **AA, AO, AB, BB, BO or OO** to represent the genotypes.

As a 9th-grade school project, **Maureen** decides to trace the inheritance of blood types through her extended family, all the way back to her great-grandmother Katherine. Here's what Maureen found out....

Maureen's great-grandmother Katherine, has A type blood. Katherine and her husband John had four children – two sons, Michael (who has blood type AB) and David (who has type O blood); a daughter (Jessica) with type O blood and another daughter (Jennifer) with type A blood. Jessica never married; her sister Jennifer did get married and had three sons (one with type A blood, one with type AB blood and one with type O blood). Both of Katherine's sons also get married – Michael marries a woman with type O blood and together they have two daughters (Anna – type A; Leanne – type B); David marries a woman with type A blood, and they have three children (daughter Fran and son Albert who both have type A blood, and a son Matthew with type O blood). Matthew marries Janine and together they have one daughter, **Maureen**. Maureen knows that her parents both have the same blood type, but she has never yet had a blood test to determine her own blood type.

Links for (Optional) Extra Practice:

<http://learn.genetics.utah.edu/content/addiction/genetics/pi.html>

<http://www2.edc.org/weblabs/WebLabDirectory1.html> (click on "Genetic Counselor" for pedigrees)

http://www.zerobio.com/drag_gr11/pedigree/pedigree4.htm

http://www.zerobio.com/drag_gr11/pedigree/pedigree_quiz.htm

***CHALLENGE PROBLEM**

_____. Look carefully at the pedigree drawn below and match it to one of the choices given. Write your answer on the line provided. Most likely, the trait being tracked in this family is:

- a) autosomal recessive
- b) autosomal dominant
- c) X-sex linked recessive

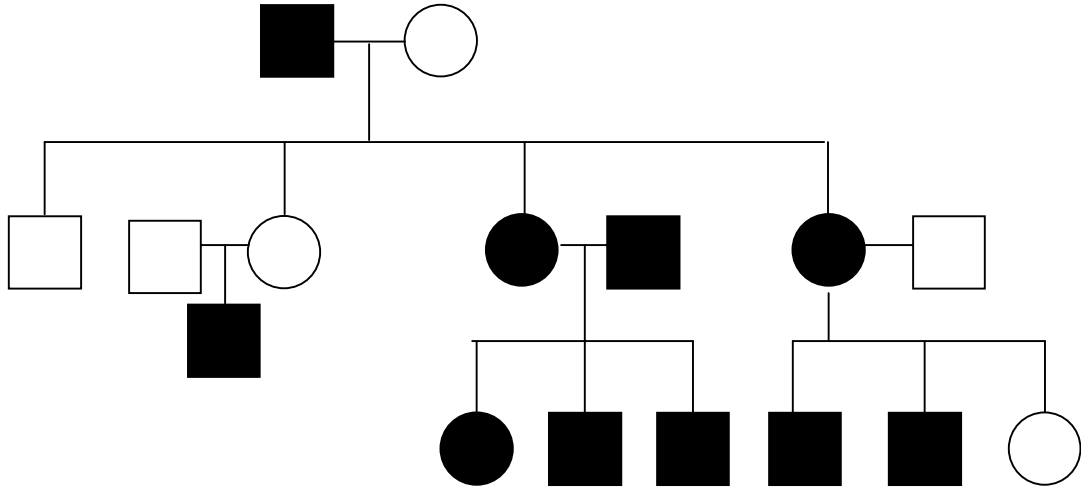

***EXTENSION: Draw Your Own Pedigree – Case Study #4**

Condition of Interest: Hemophilia

Hemophilia is a blood clotting disorder in which one of the proteins needed to form blood clots is missing or reduced (commonly, the protein known as Factor VIII). Individuals have difficulty forming blood clots following injury and may suffer significant blood loss from even minor cuts and bruises.

Inheritance Pattern: Factor VIII is an essential blood clotting protein which is formed by a normal allele found on the X chromosome; hemophilia is caused by a lack of Factor VIII which results from a recessive allele found on the X chromosome.

Remember that because this is an X-linked disorder, when you identify genotypes in this pedigree, you must use the XX/XY notation and use superscripts with each X chromosome to indicate whether the “H” (normal) or “h” (hemophilia) allele is present. (Ex. X^HY = normal male)

Hemophilia became known as the “Royal disease” after it suddenly cropped up in some of the descendents of Great Britain’s Queen Victoria and spread through the royal families of Europe. Queen Victoria and her husband Prince Albert had 9 children – 5 girls (Beatrice, Victoria, Alice, Helena, and Louise – none of whom were hemophiliacs) and 4 boys (Edward, Alfred and Arthur had normal blood clotting; their son Leopold, however, was a hemophiliac). Beatrice married a man named Henry and they had four children (sons Leopold and Maurice who were hemophiliacs, daughter Eugenie who was not a hemophiliac, and another son who was also not a hemophiliac). Eugenie married Alfonso XIII of Spain (non-hemophiliac) and they had 6 children (2 normal sons, 2 normal daughters and 2 hemophiliac sons). One of those normal sons married a non-hemophiliac woman and gave birth to one son – a non-hemophiliac they named Juan Carlos (the reigning King of Spain).

Draw your pedigree for Case Study #4 on the back of this page.